

Aftersales Training – N14 Motor. Ansaugluft- und Abgassystem.

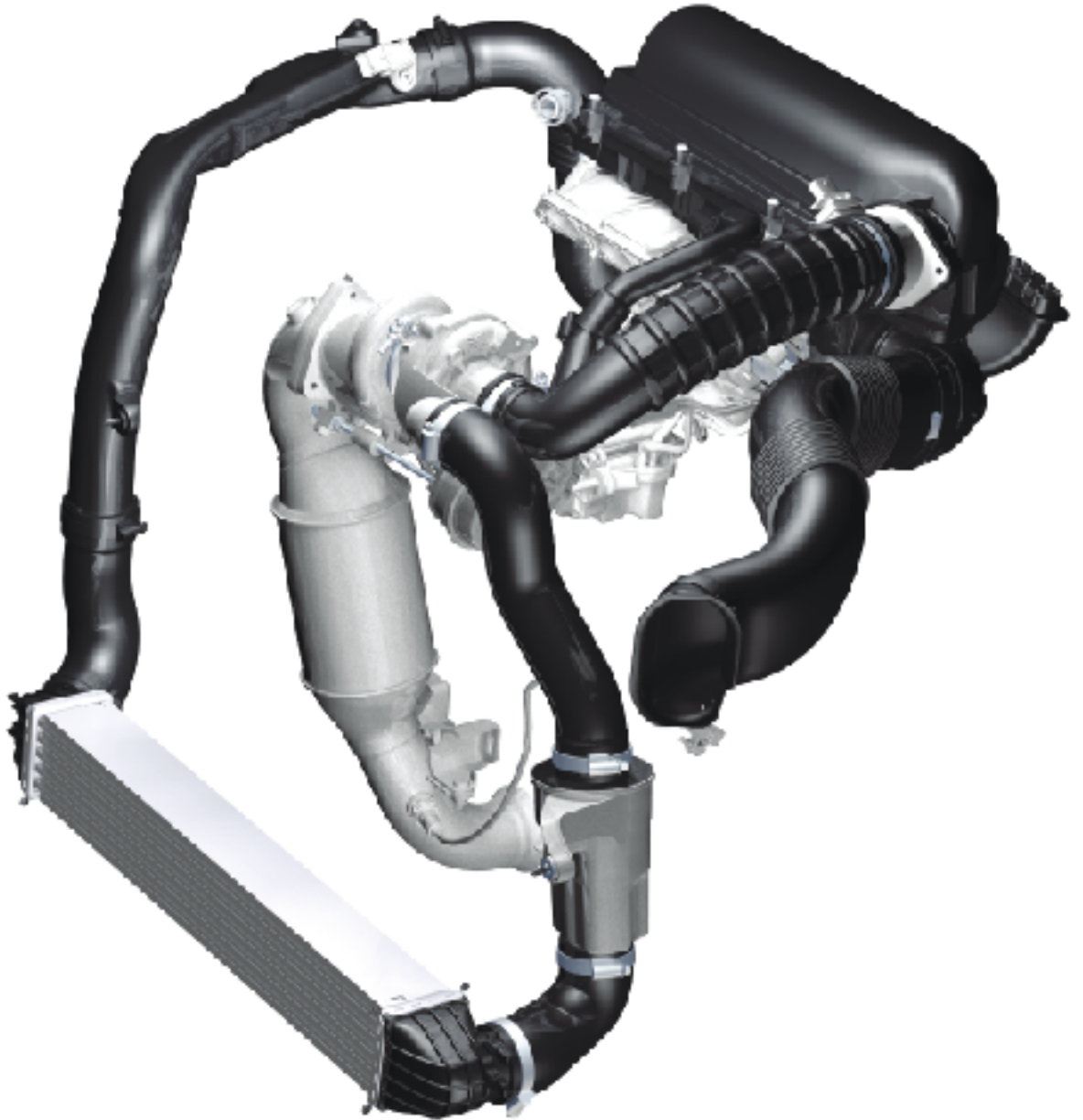

MINI Service

Aftersales Training – Getriebe R56. Varianten.

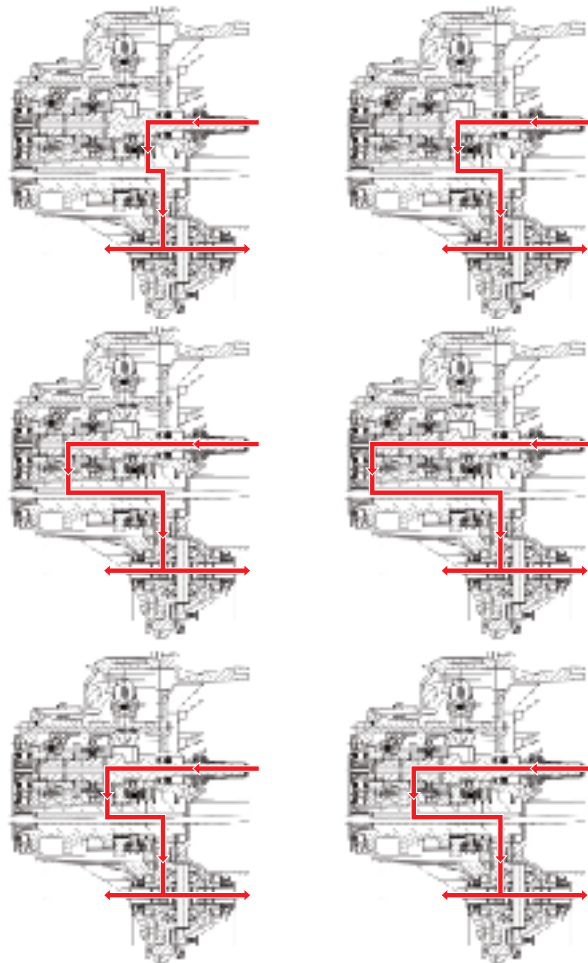
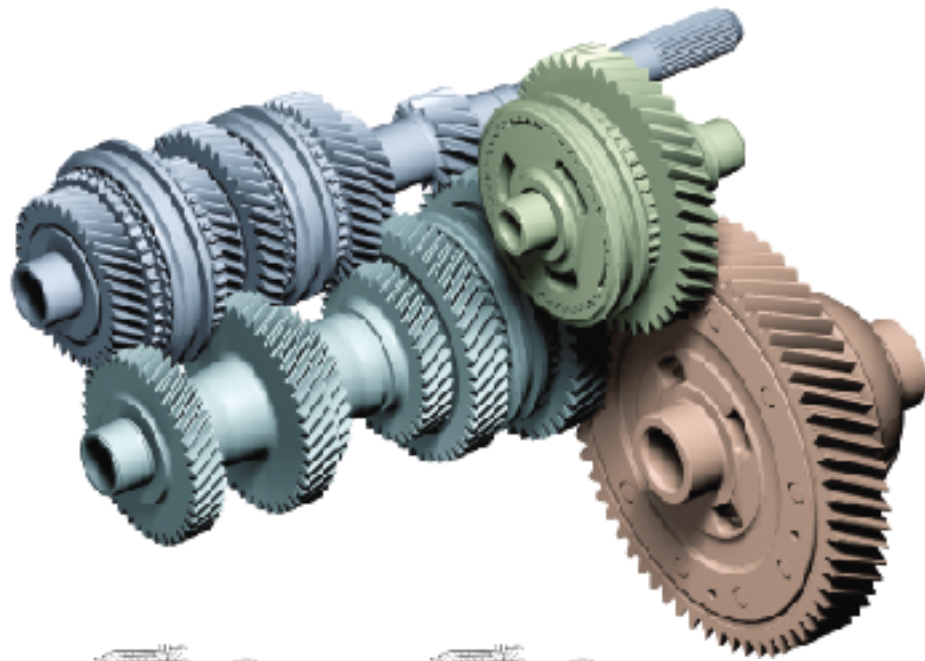

Aftersales Training – N14 Motor. Kühlmittelkreislauf.

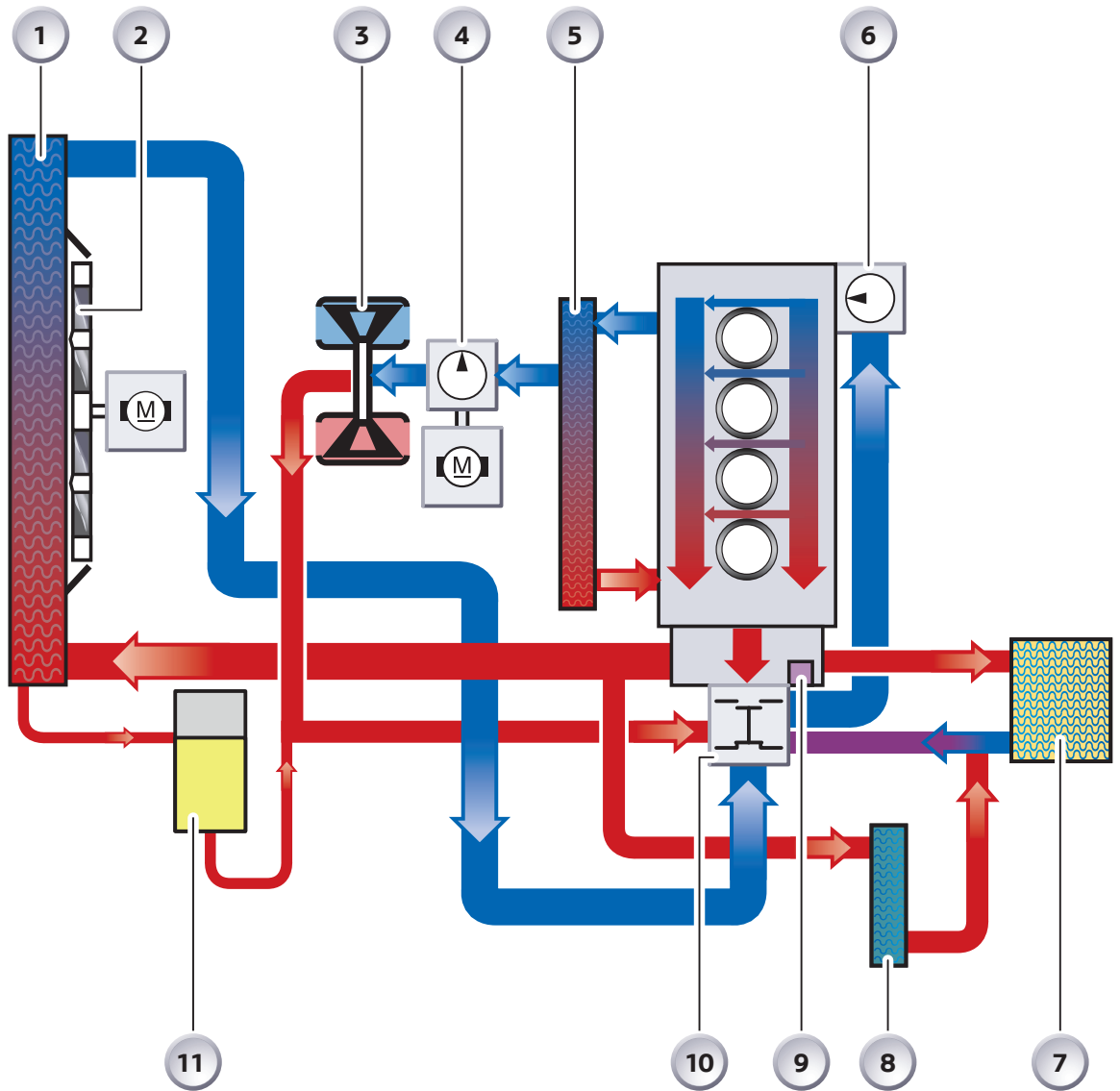

- 1 Kühler Wärmetauscher Kühlmittel / Luft
- 2 Elektrolüfter
- 3 Abgasturbolader
- 4 Elektrische Zusatzkühlmittelpumpe
- 5 Motorölkühler
Wärmetauscher Motoröl / Kühlmittel
- 6 Kühlmittelpumpe

- 7 Heizungswärmetauscher
- 8 Getriebekühler
Wärmetauscher Getriebeöl / Kühlmittel
- 9 Temperatursensor
- 10 Kennfeldthermostat
- 11 Ausgleichsbehälter

Aftersales Training – N14 Motor. Kurbelgehäuseentlüftung.

Unterdruck im Sammler
für Ansaugluft

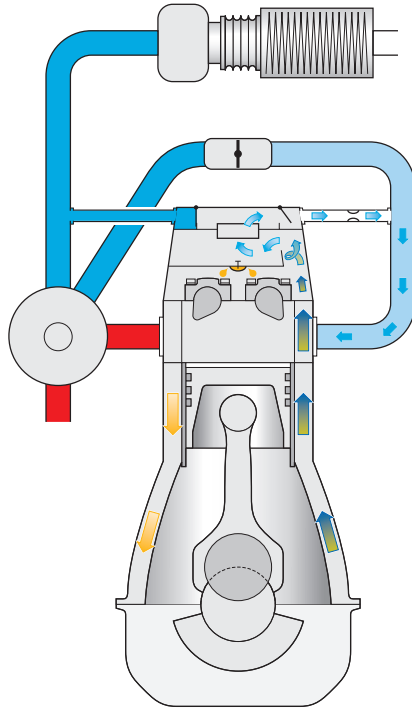

Überdruck im Sammler
für Ansaugluft

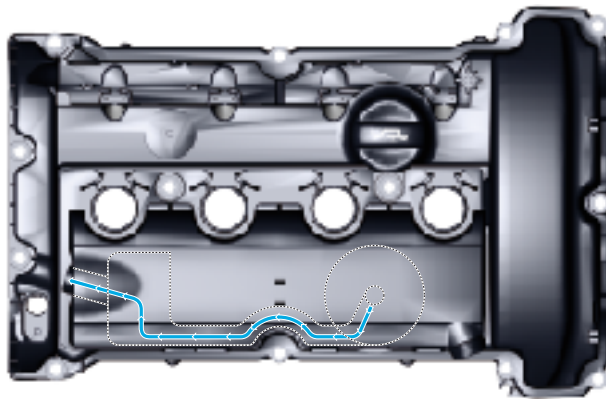
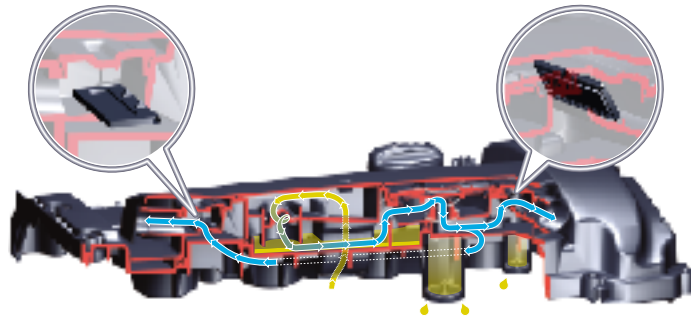
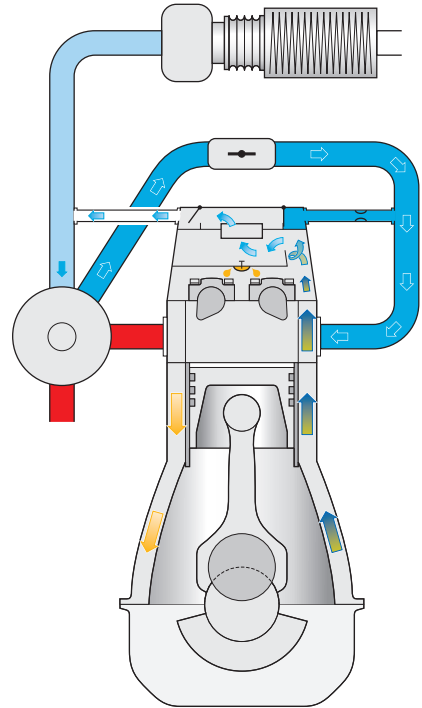

Aftersales Training – N12 Motor. Leistungsdiagramm.

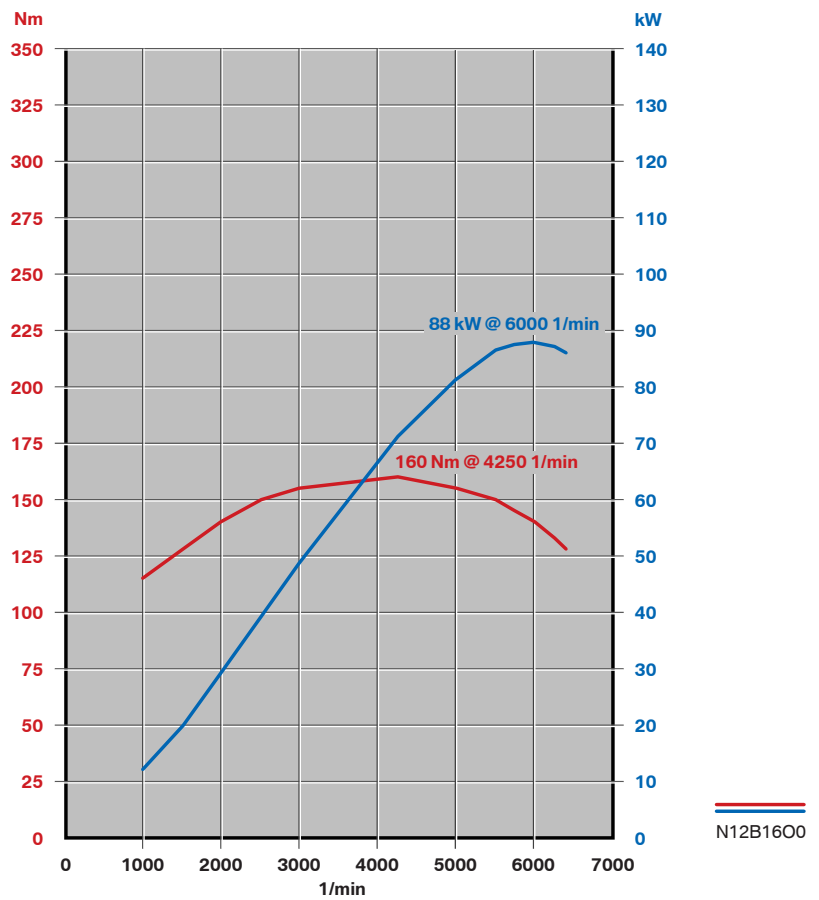
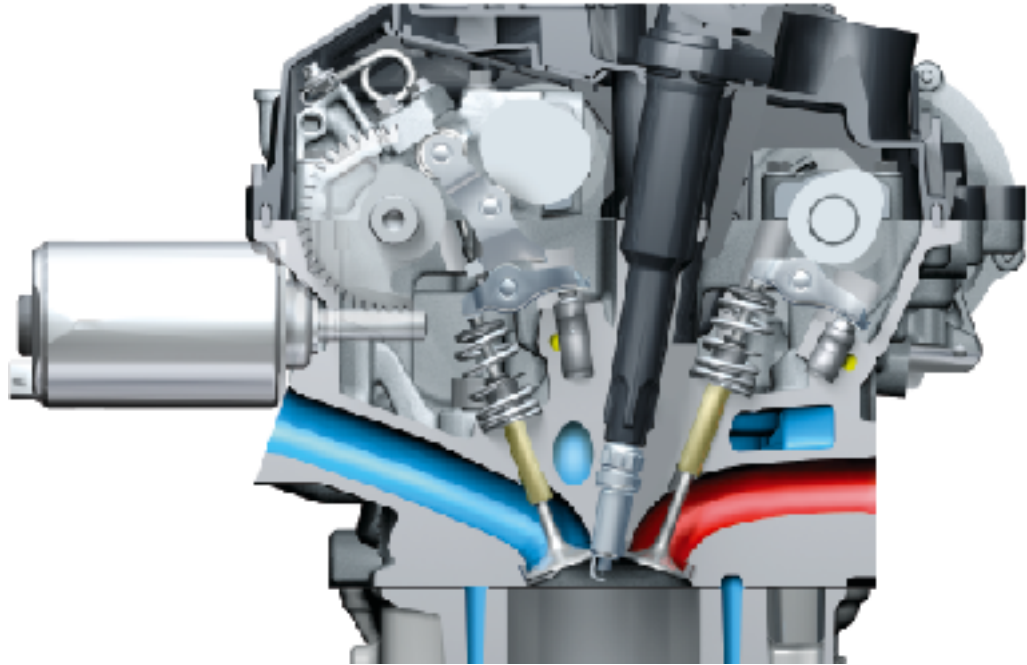

Aftersales Training – N14 Motor. Leistungsdiagramm.

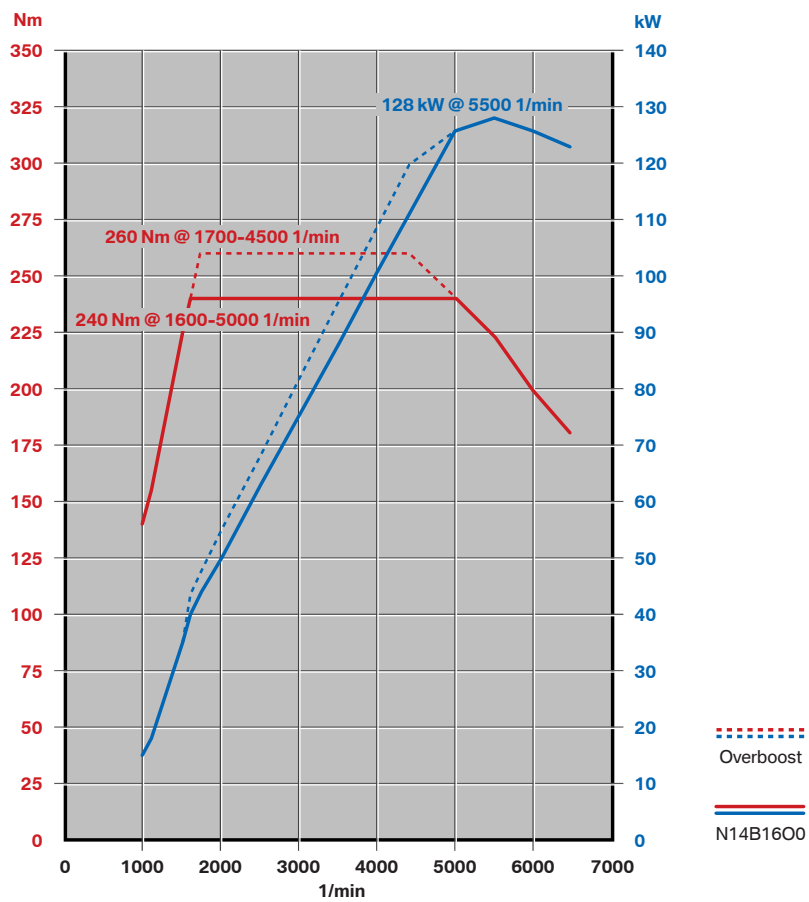
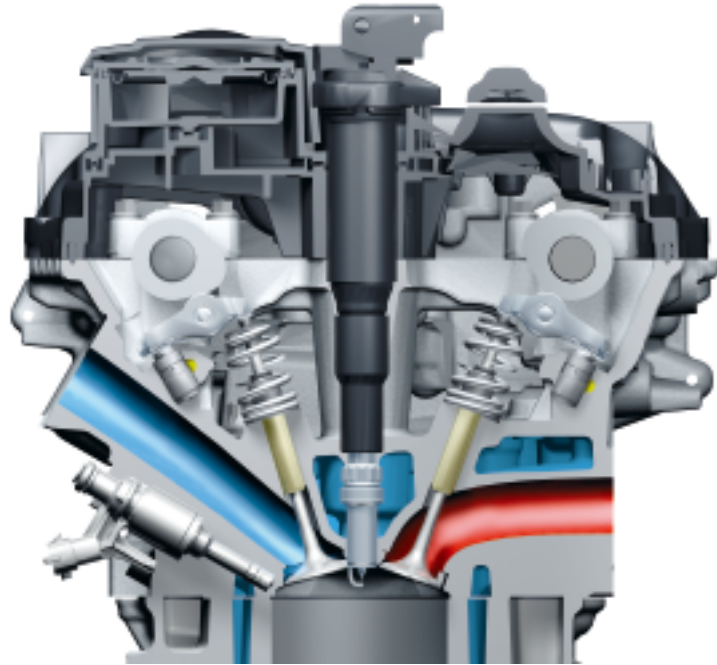

Aftersales Training – N12 Motor. Ölkreislauf.

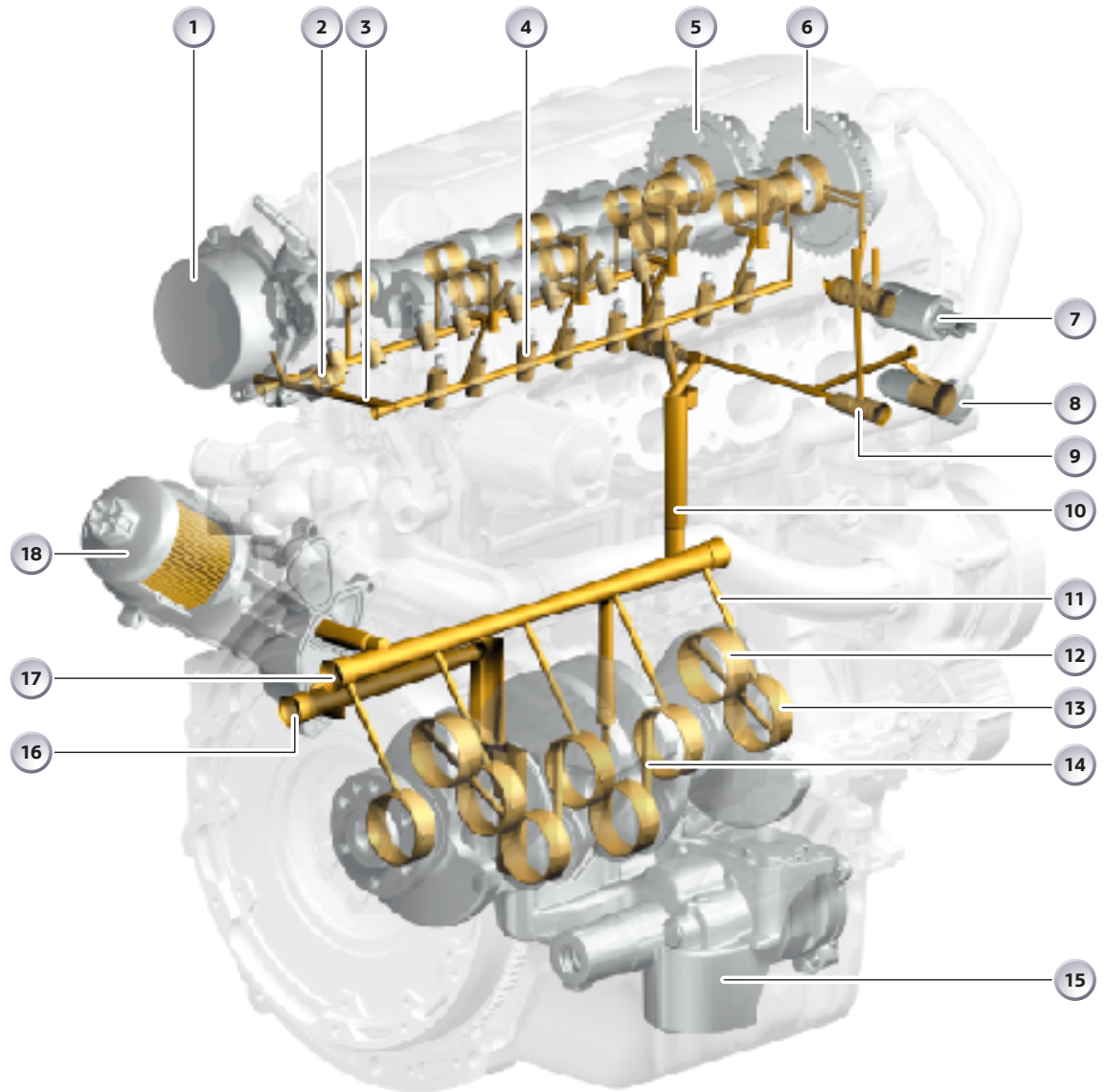

1 Unterdruckpumpe

2 Öldruckschalter

3 Ölkanal Zylinderkopf

4 hydraulischer Ventilspiegelausgleich

5 VANOS Auslassnockenwelle

6 VANOS Einlassnockenwelle

7 VANOS-Magnetventil Einlass

8 Kettenspanner

9 Rückschlagventil

10 Hauptölkanal Steigleitung zum Zylinderkopf

11 Ölkanal zum Hauptlager Kurbelwelle

12 Pleuellager

13 Kurbelwellenlager

14 Ölkanal vom Kurbelwellenlager zum Pleuellager

15 Ölpumpe

16 Rohölkanal zum Ölfilter

17 Reinölkanal (Hauptölkanal)

18 Ölfilter

Aftersales Training – N12 Motor. VALVETRONIC.

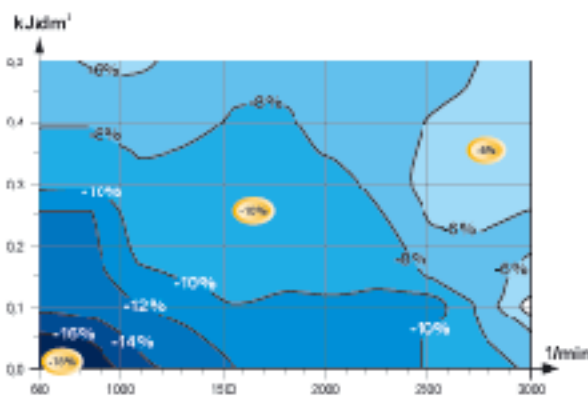
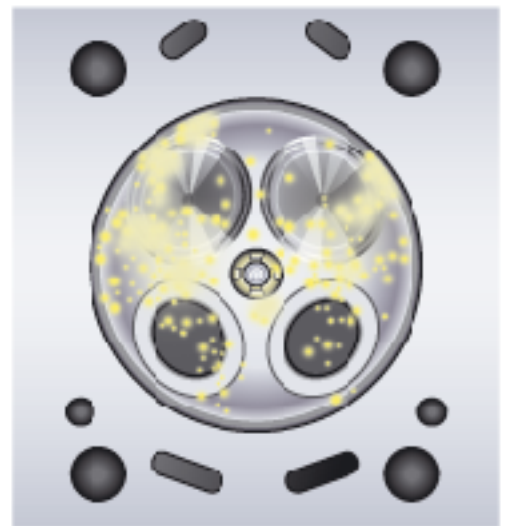
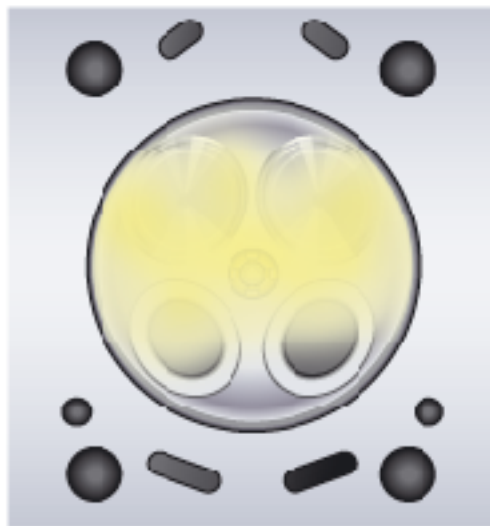
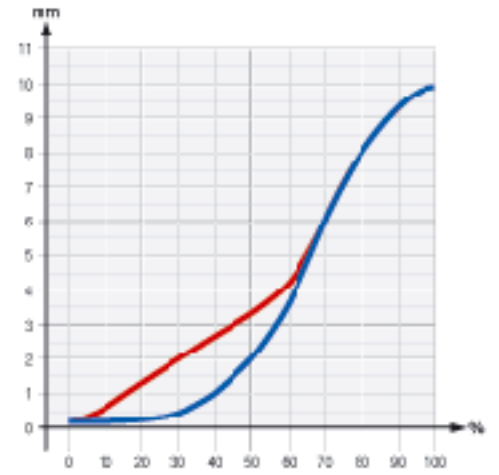
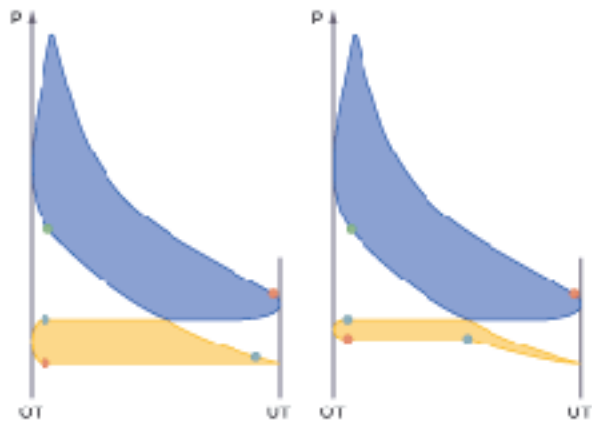

MINI Service

Aftersales Training – N12 / N14 Motor. VANOS.

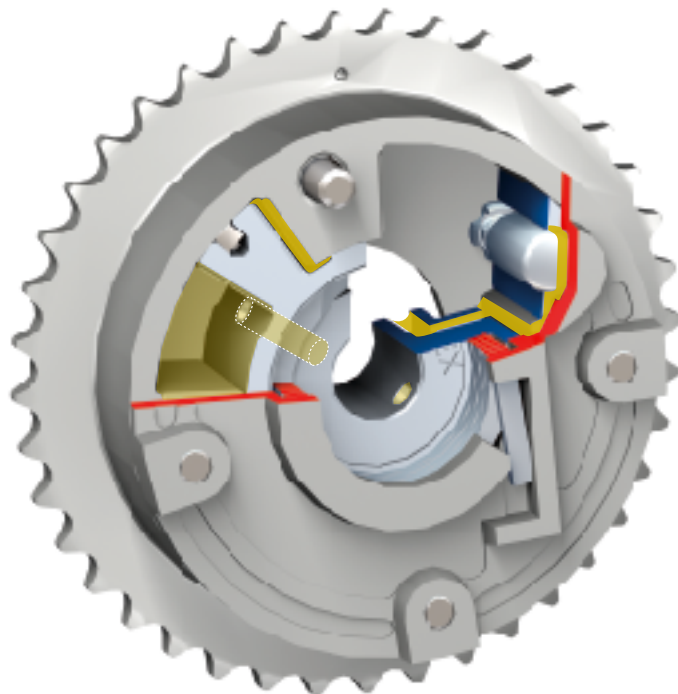

Steuerzeiten N12 Motor

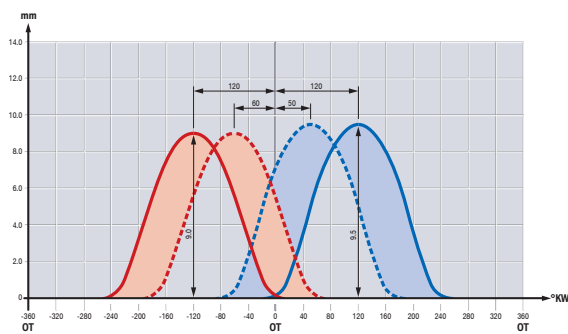

Steuerzeiten N14 Motor

